

**Porsche Ceramic Composite Brake – PCCB, 20-inch (I-no. PB1)**

Vehicle Type: **Cayenne Turbo**

Model Year: **As of 2011 up to 2012**

Information: **Retrofitting**

Revision: This bulletin replaces bulletin Group 4, #48/10, dated February 15, 2011.

Restriction: **ONLY** approved for vehicles with a wheel size  $\geq$  20-inch!  
**NOT** approved for vehicles with increased performance engine - 397 kW (540 hp)!  
**ONLY** approved for vehicles up to production week 30 in 2011 and the following vehicle identification numbers (VINs)!

Vehicle type	up to VIN	up to Production No.
V8 Turbo USA	WP1 AC2 A2 9CL A8 1170	382 1180

Note: The PCCB brake system offers improved performance compared to the standard brake system. The decisive advantages of PCCB are:

- Faster response
- Very high fading stability thanks to consistently high friction values
- High safety reserves, even in extreme driving situations
- Long service life of brake components
- Reduced rotating mass and unsprung weight
- Vehicle weight reduced by approx. 33 lbs (15 kg) compared to grey cast iron brake discs

The PCCB brake system can be retrofitted worldwide and is also available as a factory installed option for new vehicles by requesting optional equipment “I-no. PB1” (comprising I-nos. “1LX” and “2EH”).

# 4

Cayenne (92A)  
4701 ENU **48/10**

## Installation and Conversion Instructions



Figure 1

Parts Info: **958.044.605.00** ⇒ Porsche Ceramic Composite Brake – PCCB, set

Parts List:

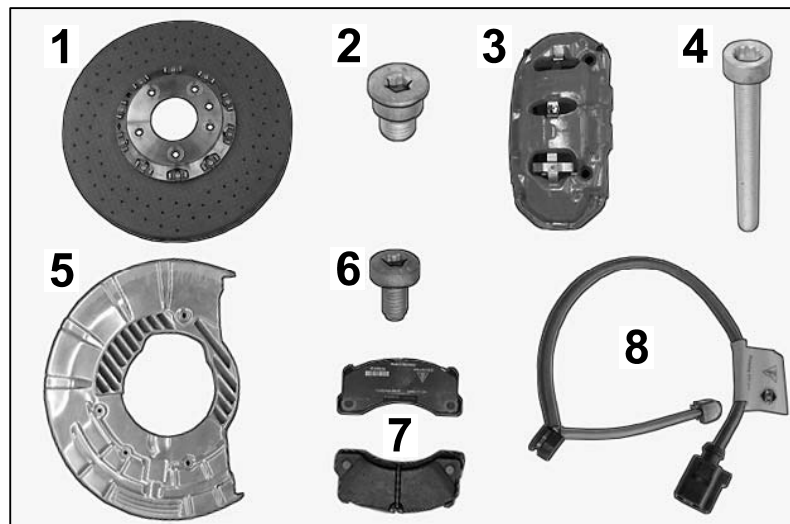

Figure 2

Parts included for front axle (FA):

958.351.032.50	1 x	Brake disc, dia.: 410 x 38, right ⇒ <i>Figure 2-1-</i>
N.910.282.02	4 x	Rounded hexagon socket head bolt, M12 x 1.5 x 16 (also for rear axle = RA) ⇒ <i>Figure 2-2-</i>
7PP.615.124.T	1 x	Brake caliper, 20-inch incl. spring and cable guide, right ⇒ <i>Figure 2-3-</i>

WHT.004.572	4 x	Cheese head bolt, M14 x 1.5 x 135 ⇒ <i>Figure 2-4-</i>
958.351.802.50	1 x	Cover plate, right ⇒ <i>Figure 2-5-</i>
N.907.371.05	16 x	Hexagon round-head bolt, M6 x 12 (cover plates on FA and RA) ⇒ <i>Figure 2-6-</i>
958.351.939.70	1 x	Brake pad repair set, asbestos-free ⇒ <i>Figure 2-7-</i>
970.609.143.00	2 x	Warning contact ⇒ <i>Figure 2-8-</i>
958.351.031.50	1 x	Brake disc, dia.: 410 x 38, left (not shown)
7PP.615.123.T	1 x	Brake caliper, 20-inch incl. spring and cable guide, left (not shown)
958.351.801.50	1 x	Cover plate, left (not shown)



Figure 3

Parts included for rear axle (RA):

955.352.032.00	1 x	Brake disc, dia.: 370 x 30, right ⇒ <i>Figure 3-9-</i>
N.910.380.02	2 x	Screw plug, M12 x 1.5 x 5.0 (rear-axle brake disc, for adjusting parking brake) ⇒ <i>Figure 3-10-</i>
958.352.426.00	1 x	Brake caliper, 19-inch incl. spring, right ⇒ <i>Figure 3-11-</i>
N.911.837.01	4 x	Screw, M12 x 1.5 x 115 (brake caliper) ⇒ <i>Figure 3-12-</i>
958.352.802.10	1 x	Brake mounting plate, right ⇒ <i>Figure 3-13-</i>
958.352.939.70	1 x	Brake pad repair set, asbestos-free ⇒ <i>Figure 3-14-</i>
970.609.145.00	2 x	Warning contact ⇒ <i>Figure 3-15-</i>
955.352.031.00	1 x	Brake disc, dia.: 370 x 30, left (not shown)
958.352.425.00	1 x	Brake caliper, 19-inch incl. spring, left (not shown)
958.352.801.10	1 x	Brake mounting plate, left (not shown)

Parts included for rear axle differential and wheel bearing, rear:

N.105.524.02	4 x	Hexagon-head bolt, M12 x 1.5 x 70 (trailing arm/chassis subframe – top, not shown)
N.104.029.04	4 x	Hexagon nut, M12 x 1.5 (trailing arm/chassis subframe – top, not shown)
WHT.004.887	2 x	Combination screw, M14 x 1.5 x 95 (trailing arm/wheel carrier – bottom, not shown)
WHT.004.886	2 x	Hexagon nut, M14 x 1.5 (trailing arm/wheel carrier – bottom, not shown)
N.911.833.01	2 x	Hexagon-head bolt, M16 x 1.5 x 120 (tie rod/wheel carrier, not shown)
N.105.868.02	2 x	Hexagon nut, M16 x 1.5 (tie rod/wheel carrier, not shown)
WHT.005.461	2 x	Hexagon-head bolt, M12 x 1.5 x 120 (shock absorber strut/anti-roll bar to wheel carrier, not shown)
N.104.029.04	2 x	Hexagon nut, M12 x 1.5 (shock absorber strut/anti-roll bar to wheel carrier, not shown)
WHT.005.378	4 x	Fit bolt, M10 x 40 (EPB/wheel carrier, not shown)
WHT.004.835	8 x	Multi-tooth screw, M12 x 1.25 x 45 (wheel bearing housing/wheel bearing, not shown)
955.332.596.10	1 x	Shaft sealing ring, 50 x 72 x 9 (left, rear axle differential without lock, not shown)
955.332.596.00	1 x	Shaft sealing ring, 50 x 82 x 9 (right, not shown)
955.332.596.30	1 x	Shaft sealing ring, 80 x 100 x 10 (left, rear axle differential with lock, not shown)
7PP.501.811.A	1 x	Protective ring (drive shaft with lock, not shown)
7PP.501.811	1 x	Protective ring (drive shaft without lock, not shown)
955.341.640.00	2 x	Lock nut, M24 x 1.5 (not shown)
955.332.125.00	2 x	Circlip (drive shaft, not shown)

Materials:	000.043.203.66	X x <sup>1</sup>	Super Dot 4 brake fluid; 1-litre container
	000.043.020.00	X x <sup>1</sup>	Optimoly TA aluminium paste, 100g tube
	000.043.300.37	X x <sup>1</sup>	75W90 transmission oil, 1-liter container
	000.043.024.00	1 x	Extreme-pressure grease; 80g tube

<sup>1</sup> Quantity, as required.

Tools:	<b>Nr.144 - Piston reset tool</b>	Brake bleeding device
	<b>T10206 - Assembly fixture</b>	<b>T10439 - Assembly pin</b>
	<b>9818 - PIWIS Tester II</b>	<b>9819 - PIWIS Tester II WLAN</b>

Brake pedal lock (commercially available)  
Mounting lever

Universal drive shaft/wheel hub extractor

Work Procedure: 1 Preparatory work.

- 1.1 Drive the vehicle onto the lifting platform and raise it ( ⇒ *Workshop Manual '4X00IN Lifting the vehicle'*)
- 1.2 Connect battery charger ( ⇒ *Workshop Manual '2X00IN Battery trickle charging'*).



### Information

The **9818 - PIWIS Tester 2** instructions take precedence since the description may be different with later Tester releases.

The procedure described here has been structured in general terms; different text or additions may appear on the **9818 - PIWIS Tester 2**.

- 1.3 Move the parking brake into installation position using **9818 - PIWIS Tester II**.
  - 1.3.1 **9818 - PIWIS Tester II** must be connected and ignition switched on.
  - 1.3.2 Select parking brake.
  - 1.3.3 Select Drive links/Tests and move to installation position.
- 1.4 Bleed the air springs on the rear axle ( ⇒ *Workshop Manual '4301IN Bleeding and filling the levelling system'*).
- 1.5 Fit brake pedal lock ( ⇒ *Figure 4*).
- 1.6 Remove wheels ( ⇒ *Workshop Manual '440519 Removing and installing wheel'*).



Figure 4

## 2 Install PCCB on the front axle – FA

- 1 – Front brake caliper, left
- 2 – Front brake disc, left
- 3 – Front cover plate, left
- 4 – Front wheel hub, left

## 2.1 Preparatory work

2.1.1 Remove front brake caliper (left ⇒ *Figure 5 -1-/right*) ( ⇒ *Workshop Manual '473919 Removing and installing front brake calliper*).

2.1.2 Remove front brake disc (left ⇒ *Figure 5 -2-/right*) ( ⇒ *Workshop Manual '465019 Removing and installing front brake disc*).

2.1.3 Remove cover plate on front brake disc (left ⇒ *Figure 5 -3-/right*).

2.1.4 Clean the levelling and centering surfaces on the wheel hubs ( ⇒ *Figure 5 -4-*). Apply a very thin coat of Optimoly TA to the centering surfaces.

2.2 Complete the new front-axle brake caliper (left/right) (see also ⇒ *Workshop Manual '463456 Replacing front brake pads (PCCB)*).

- 1 – Brake caliper, 20-inch, FA, left
- 2 – Warning contact cable guide
- 3 – Pad spring (2 x)
- 4 – Brake pad (2 x)
- 5 – Warning contact connector

2.2.1 Position new brake pads (2 x, ⇒ *Figure 6 -4-*) on the pad retaining pins.

2.2.2 Fit new warning contact (2 x) in each pad and position in the brake pad cable guide.

2.2.3 Slide the brake pad as far as it will go onto the pad retaining pin on the brake caliper ( ⇒ *Figure 6*).

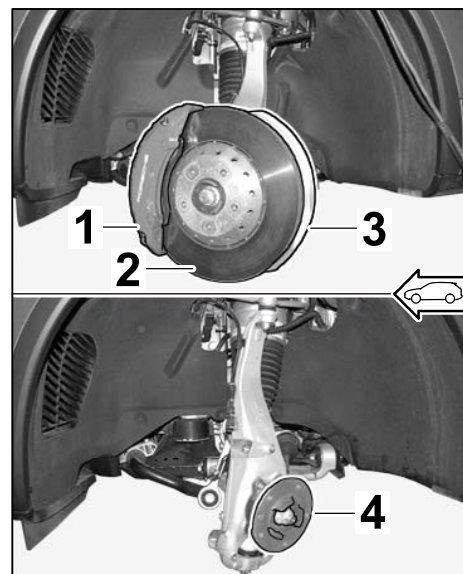

Figure 5

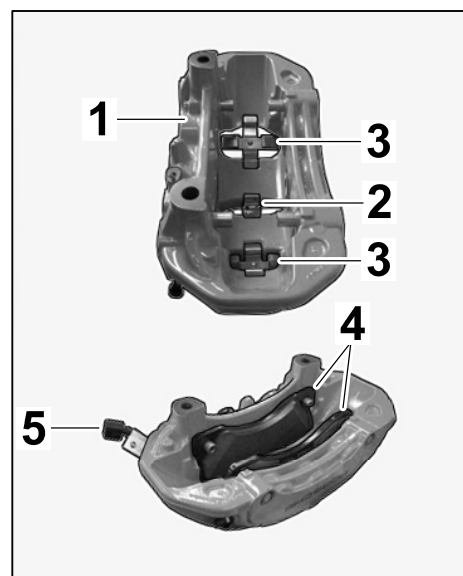

Figure 6

**Information**

Observe vehicle-side assignment of parts during installation by checking the part number or any other markings (**L** = **L**eft/**R** = **R**ight; direction of rotation = arrow)!

## 2.3 Install PCCB on the front axle

2.3.1 Fit new cover plate (left/right) on each wheel carrier (left: ⇒ Figure 7 /right) using a new M6 x 16 screw (4 x).

**Tightening torque 8 Nm (6 ftlb.)**  
 ( ⇒ Workshop Manual '4X00IN Tightening torques for brake mechanism')

- 1** – Cover plate, FA, left
- 2** – Brake disc, dia.: 410 x 38, FA, left
- 3** – Fit bolt, M12 x 1.5 x 19.3
- 4** – Brake caliper, 20-inch, FA, left
- 5** – Cheese head bolt, M14 x 1.5 x 135

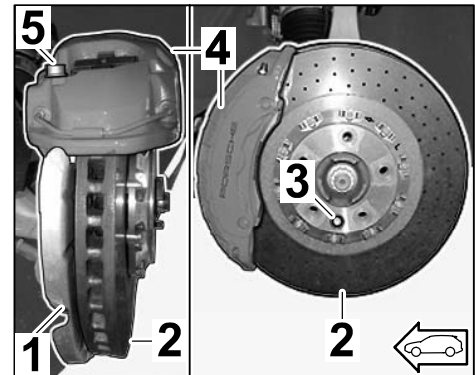

Figure 7

2.3.2 Fit new brake disc on each wheel carrier (left/right) using a new fit bolt (M12 x 1.5 x 19.3, 1 per brake disc) ( ⇒ Workshop Manual '465119 Removing and installing front brake disc (PCCB)').

**Tightening torque 15 Nm (11 ftlb.)**  
 ( ⇒ Workshop Manual '4X00IN Tightening torques for brake mechanism').

2.3.3 Fit new 20-inch front-axle brake caliper on each wheel carrier (left/right) using a new cheese head bolt (M14 x 1.5 x 135, 2 per brake caliper) ( ⇒ Workshop Manual '473919 Removing and installing front brake calliper (PCCB)').

Brake calliper to front-axle wheel carrier: **Tightening torque 140 Nm (104 ftlb.)**  
 Brake line to brake caliper: **Tightening torque 14 Nm (10.5 ftlb.) +/-1 Nm (+/-0.5 ftlb.)**  
 ( ⇒ Workshop Manual '4X00IN Tightening torques for brake mechanism').

## 3 Install PCCB on the rear axle – RA

### 3.1 Preparatory work

3.1.1 Remove rear brake caliper (left/right) ( ⇒ Workshop Manual '474119 Removing and installing rear brake calliper').

3.1.2 Remove rear brake disc (left/right) ( ⇒ Workshop Manual '465319 Removing and installing rear brake disc').



### Information

The wheel hub/wheel bearing unit (left/right) must be removed in order to replace the brake mounting plate (rear axle, left/right).

The drive shafts and wheel carriers (left/right) must also be removed and installed.

## 3.2 Remove wheel hub/wheel bearing unit

3.2.1 Remove brake shoes for electric parking brake = EPB (left/right) (⇒ *Workshop Manual '468356 Replacing brake shoes'*).

- 1 – Brake shoes (EPB), right
- 2 – Wheel hub/wheel bearing unit, right
- 3 – Brake mounting plate, right
- 4 – Upper wishbone, right

3.2.2 Remove EPB actuator (left/right) (⇒ *Workshop Manual '468519 Removing and installing spreader device (EPB)'*).

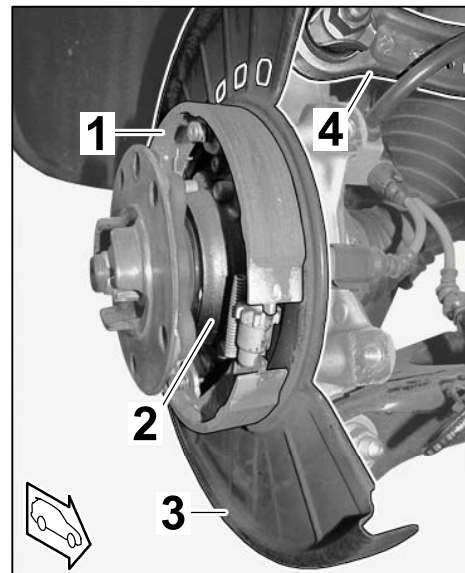

Figure 8

3.2.3 Remove rear wheel bearing housing (wheel carrier) (left/right) with upper wishbones (⇒ *Workshop Manual '425219 Removing and installing rear wheel bearing housing (wheel carrier)'*).

- 1 – Rear-axle drive shaft, left
- 2 – Wheel carrier, left
- 3 – Upper wishbone, left
- 4 – Brake mounting plate, left

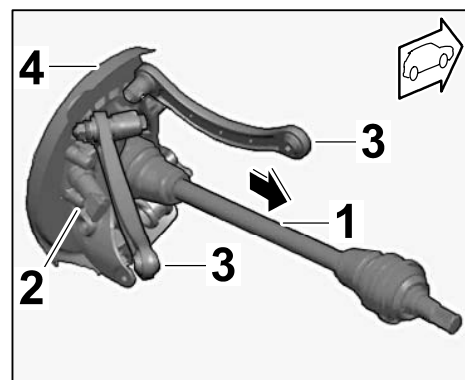

Figure 9 (shown as an example)

3.2.4 Remove rear-axle drive shaft (left/right) from the wheel bearing housing (wheel carrier, left/right) (⇒ *Figure 9 (shown as an example) -arrow-*, see also ⇒ *Workshop Manual '422119 Removing and installing rear drive shaft'*).



### Information

- The wheel bearing must not come into contact with magnetic objects (e.g., magnetic screwdriver, magnet).
- Screws and nuts are Geomet-coated and must not be greased.
- Grease the toothing of the drive shaft slightly with Optimoly TA aluminum paste.
- Drive shafts must not be left hanging from the joint stop! Tie them up.
- Use new screws and lock nuts.
- Observe correct tightening torques. ⇒ *Workshop Manual '4X00IN Tightening torques for rear axle'*



### Information

Given the high forces involved, fix the complete wheel carrier with wishbones to the chassis subframe when removing/fitting the screws used to secure the wheel hub/wheel bearing unit to the wheel carrier.

3.2.5 Remove wheel hub/wheel bearing unit (left/right) (see also ⇒ *Workshop Manual '425855 Replacing rear wheel bearing'*).

- 1** – Multi-tooth screw, M12 x 1.25 x 45
- 2** – Wheel hub/wheel bearing unit, right
- 3** – Wheel carrier, right
- 4** – Standard brake mounting plate, right

Remove multi-tooth screw M12 x 1.25 x 45 (4 x, ⇒ *Figure 10 (shown as an example) -1-*).

Remove wheel hub/wheel bearing unit.

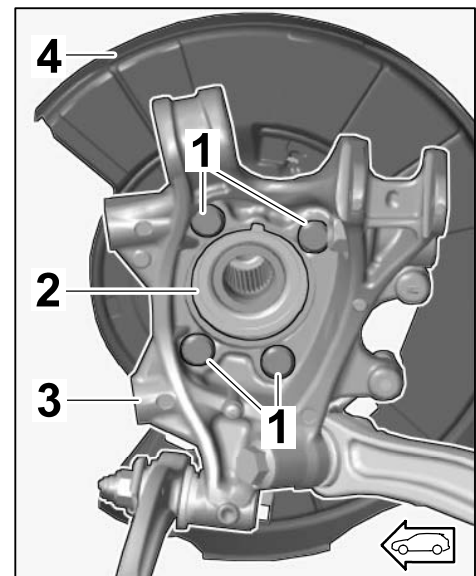

Figure 10 (shown as an example)

3.3 Replace brake mounting plate on rear axle  
(see also ⇒ *Workshop Manual '425855 Replacing rear wheel bearing'*).

- 1 – Standard brake mounting plate, left
- 2 – Hexagon round-head bolt, M6 x 12
- 3 – Wheel bearing housing (wheel carrier), left

3.3.1 Remove standard brake mounting plate (left/right).

3.3.2 Install new PCCB brake mounting plate (left/right) on the wheel carrier (left/right) using a new hexagon round-head bolt (M6 x 12, 4 on each side).

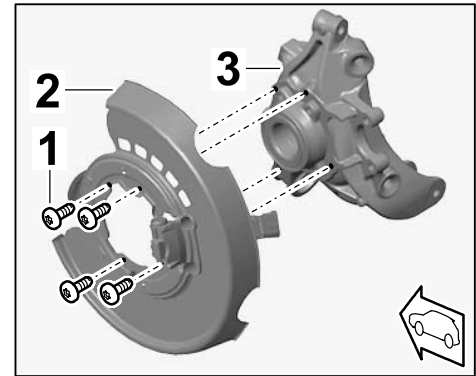

Figure 11 (shown as an example)

**Tightening torque 8 Nm (6 ftlb.)**

( ⇒ *Workshop Manual '4X001N Tightening torques for brake mechanism'* )



## Information

- All screws and bolts on the axle must be tightened in vehicle position. Vehicle position means: vehicle standing on its wheels, or the wheel suspension is raised with a universal vehicle lift. Dimension  $\Rightarrow$  Dimension X - lower edge of wing to center of axle (shown as an example) -X-r, from lower edge of wing to center of axle corresponds to vehicle position. For the current height values, please refer to the adjustment values for suspension alignment  $\Rightarrow$  Workshop Manual '4495TW Adjustment values for suspension alignment'.

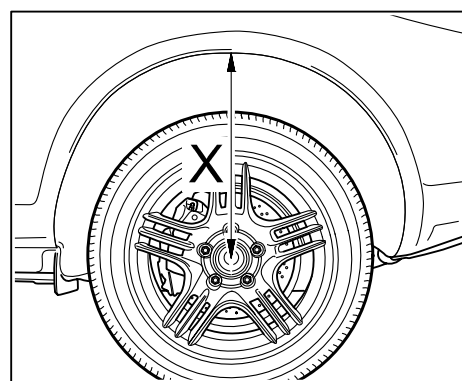

Dimension X - lower edge of wing to center of axle (shown as an example)

- Visually inspect all parts.
  - Replace self-locking nuts.
  - Replace all expansion screws (screws fitted using torque angle tightening procedure).
  - Use correct tightening torques and torque angle.  $\Rightarrow$  Workshop Manual '4X00IN Tightening torques for rear axle'
- 3.4 Install wheel hub/wheel bearing unit

- 3.4.1 Fit the wheel hub/wheel bearing unit on the relevant wheel bearing housing (wheel carrier, left/right) and secure it with a new multi-tooth screw (M12 x 1.25 x 45, 4 on each side) (see also ⇒ *Workshop Manual '425855 Replacing rear wheel bearing'*).

- 1 – Multi-tooth screw, M12 x 1.25 x 45
- 2 – Wheel hub/wheel bearing unit, right
- 3 – Wheel carrier, right
- 4 – PCCB brake mounting plate, right

**Tightening torque 80 Nm  
(59 ftlb.) +120°**

( ⇒ *Workshop Manual '4X00IN Tightening torques for rear axle'*)

- 3.4.2 Remove wheel bearing housing (wheel carrier, left/right) with wishbone on the chassis subframe and set it down carefully.
- 3.4.3 Install rear-axle drive shaft (left/right) in the wheel bearing housing (wheel carrier, left/right) ( ⇒ *Workshop Manual '422119 Removing and installing rear drive shaft'*).
- 3.4.4 Replace sealing rings (left/right) for the halfshaft flange ( ⇒ *Workshop Manual '392255 Removing and installing sealing ring for halfshaft flange (without locking differential)'*).

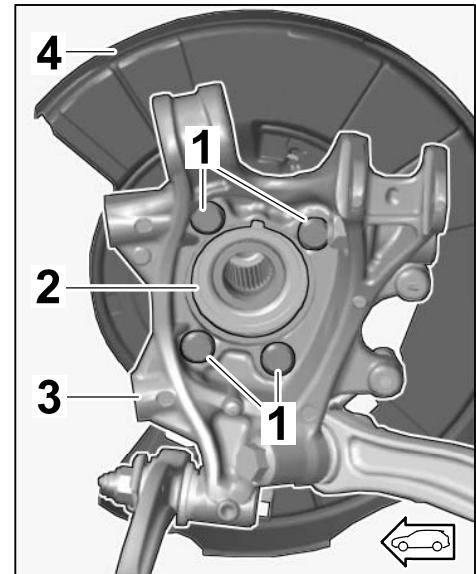

Figure 12 (shown as an example)



**Information**

Before installing the shaft, replace the lock ring (circlip) on the shaft as well as the shaft sealing ring in the final drive ⇒ *Workshop Manual '392219 Removing and installing sealing ring for output flange'*.

Make sure not to damage the sealing ring when guiding the shaft into the final drive.

- The inner end of the drive shaft must be held with both hands at the joint and inserted into the rear axle differential with a quick jerk. The outer joint must be held by a second mechanic in order to prevent damage.
- Check that the joint is seated correctly in the rear axle differential: Hold the joint with both hands and pull outwards.
- Visually check that the plastic protective rings are flush on the rear axle differential.

3.4.5 Install wheel bearing housing (wheel carrier, left/right)with drive shaft ( ⇒ *Workshop Manual '425219 Removing and installing rear wheel bearing housing (wheel carrier)'*).

- 1** – PCCB brake mounting plate, right
- 2** – Wheel hub/wheel bearing unit, right
- 3** – Upper wishbone, right

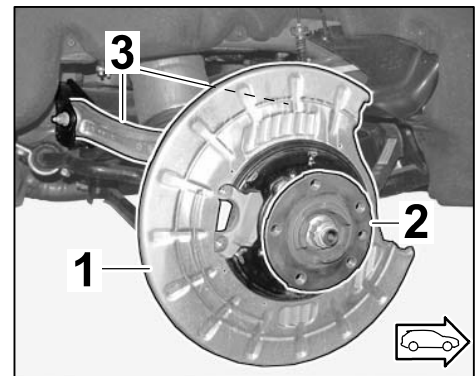

Figure 13

3.4.6 Install EPB actuator (left/right) using a new fit bolt (M10 x 40, 2 on each side) ( ⇒ *Workshop Manual '468519 Removing and installing spreader device (EPB)'*).

**Tightening torque 20 Nm (15 ftlb.) +60°**

( ⇒ *Workshop Manual '4X00IN Tightening torques for rear axle'*).

3.4.7 Install brake shoes for electric parking brake = EPB (left/right) ( ⇒ *Workshop Manual '468356 Replacing brake shoes'*).

3.5 Install PCCB brake on rear axle

3.5.1 Clean the levelling and centering surfaces on the wheel hubs. Apply a very thin coat of Optimoly TA to the centering surfaces.

**Information**

Observe vehicle-side assignment of parts during installation by checking the part number or any other markings (**L** = Left/**R** = Right; direction of rotation = arrow)!

- 3.5.2 Fit new brake disc with diameter of 370 x 30 on each wheel carrier (left/right) using a new fit bolt (M12 x 1.5 x 19.3, 1 per brake disc) (⇒ Workshop Manual '465419 Removing and installing rear brake disc (PCCB)').

- 1 – PCCB brake mounting plate, left
- 2 – Brake disc, dia.: 370 x 30, PCCB, left
- 3 – Fit bolt, M12 x 1.5 x 19.3
- 4 – Screw plug, M12 x 1.5 x 5.0
- 5 – Brake caliper, 19-inch incl. spring, PCCB, left

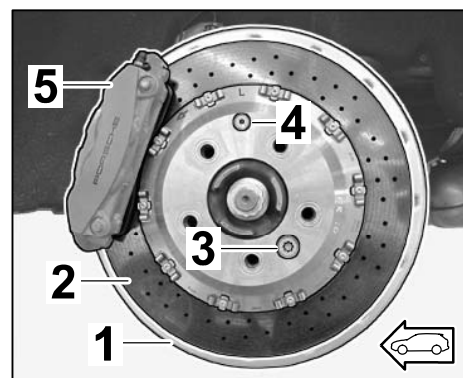

Figure 14

**Tightening torque 15 Nm (11 ftlb.)**

(⇒ Workshop Manual '4X00IN Tightening torques for brake mechanism').

- 3.5.3 Complete the new rear-axle brake caliper (left/right) (see also ⇒ Workshop Manual '463556 Replacing rear brake pads (PCCB)').
- 3.5.4 Fit new 19-inch rear-axle brake calliper on each wheel carrier (left/right) using a new bolt (AM 12 x 1.5 x 115, 2 per brake caliper) (⇒ Workshop Manual '474119 Removing and installing rear brake calliper (PCCB)').

Brake caliper to rear-axle wheel carrier: **Tightening torque 85 Nm (63ftlb.)**

Connecting line to brake caliper: **Tightening torque 14 Nm (10.5 ftlb.)**

**+/-1 Nm (+/-0.5 ftlb.)**

Brake line/wear indicator holder to brake caliper: **Tightening torque 8 Nm (6 ftlb.)**

(⇒ Workshop Manual '4X00IN Tightening torques for brake hydraulics' and ⇒ Workshop Manual '4X00IN Tightening torques for rear axle').

- 3.5.5 Adjust and calibrate parking-brake shoes (⇒ Workshop Manual '468315 Adjusting and calibrating brakes').
- 3.5.6 Fit new brake disc screw plug (M12 x 1.5 x 5.0, 1 ea., ⇒ Figure 14 -4-) on each brake disc.

**Tightening torque 15 Nm (11 ftlb.)**

(⇒ Workshop Manual '4X00IN Tightening torques for rear axle').

## 4 Concluding work

- 4.1 Position disc brake pads by actuating the brake several times and bleed the brake system ( ⇒ *Workshop Manual '470107 Bleeding the brake system'*).
- 4.2 Fit wheels ( ⇒ *Workshop Manual '440519 Removing and installing wheel'*).
- 4.3 Fill rear air springs ( ⇒ *Workshop Manual '4301IN Bleeding and filling the levelling system'*).



### Information

- All screws and bolts on the axle must be tightened in vehicle position. Vehicle position means: vehicle standing on its wheels, or the wheel suspension is raised with a universal vehicle lift. Dimension ⇒ *Dimension X - lower edge of wing to center of axle (shown as an example) -X-r*, from lower edge of wing to center of axle corresponds to vehicle position. For the current height values, please refer to the adjustment values for suspension alignment ⇒ *Workshop Manual '4495TW Adjustment values for suspension alignment'*.

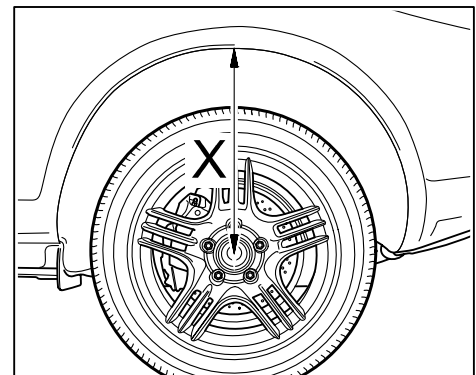

*Dimension X - lower edge of wing to center of axle (shown as an example)*

- Visually inspect all parts.
  - Replace self-locking nuts.
  - Replace all expansion screws (screws fitted using torque angle tightening procedure).
  - Use correct tightening torques and torque angle. ⇒ *Workshop Manual '4X00IN Tightening torques for rear axle'*
- 4.4 Tighten rear-axle threaded connections to the specified tightening torques ( ⇒ *Workshop Manual '4X00IN Tightening torques for rear axle'*).
  - 4.5 Add Porsche Ceramic Composite Brake – PCCB (I-no. 1LX = 20-inch) front and (I-no. 2EH = 19-inch) rear in the vehicle equipment.
    - 4.5.1 **9818 - PIWIS Tester II** must be connected and ignition switched on.
    - 4.5.2 Select the relevant vehicle, control units and then select Additional menu by pressing **[F7]**.

- 4.5.3 Select the "Maintenance of vehicle data" menu. Press **F12** until "PR numbers" appears in the Value group column.
- 4.5.4 Select "2EH - 19" rear disc brakes, yellow (PCCB)" and "1LX - 20" front disc brakes, yellow (PCCB)" and press **F8** to save these values.
- 4.5.5 When a tick appears next to the selected values, press **F12** until **F8** can be activated.
- 4.5.6 Press **F8** to write the values.
- 4.5.7 When the message "Generation of vehicle data is complete. Continue to log administration" appears, press **F12** to continue.
- 4.5.8 Press **F10** to open the log. Check that vehicle equipment values "1LX - 20" front disc brake, yellow (PCCB)" and "2EH - 19" rear disc brake, yellow" have been entered.
- 4.5.9 Close the log and press **F11** to return to the control unit selection screen.
- 4.6 Code the new vehicle equipment.
  - 4.6.1 Switch to the "Codings/adaptations" menu and select "Automatic coding with coding rules". To continue, press **F12**
  - 4.6.2 Select all control units in the control unit overview (**CTRL+A**) and switch to the "Codings/adaptations" column.
  - 4.6.3 Select Automatic coding. Press **F12** to continue.
- 4.7 Once coding is complete, read out the fault memories of all systems, correct any existing faults and erase the fault memories. ⇒ *Workshop Manual '033500 Fault memory for on-board diagnosis'*
- 4.8 **9818 - PIWIS Tester II** must be disconnected and ignition switched off.
- 4.9 Disconnect battery charger ( ⇒ *Workshop Manual '2X00IN Battery trickle charging'*).
- 4.10 Align the vehicle ( ⇒ *Workshop Manual '449503 Suspension alignment, complete'*)

Working Time: 47 01 31 00 –Converting brake system from grey cast iron to ceramic brake discs–

Labor time: **740 TU**

Includes: Removing and installing brake caliper and brake disc.  
Removing and installing front-axle cover plate and rear-axle brake mounting plate, partially disassembling rear axle.  
Adjusting brake shoes and bleeding the brake system.  
Updating vehicle data using the PIWIS Tester.

Without: Performing test drive or brake test on brake test stand.  
Adjusting the vehicle (separate LO No.).

44 95 15 50 –Adjusting vehicle at front + rear–

Labor time: **70 TU**

---

# Installation and Conversion Instructions

---

Cayenne (92A)

**48/10** ENU 4701

**4**

44 95 15 53 –Adjusting vehicle at front + rear–

Labor time: **140 TU**

**Important Notice:** Porsche Cars N.A Technical Bulletins are intended for use by professional technicians, not a "Do-it-yourselfer." They are written to inform these technicians of conditions that may occur on some vehicles, or to provide information that could assist in the proper service of a vehicle. Special tools may be required to perform certain operations identified in these bulletins. Use of tools and procedures other than those recommended in these bulletins may be detrimental to the safe operation of your vehicle. Properly trained technicians have the equipment, tools, safety instructions and know-how to do a job properly and safely. If a condition is described, do not assume that the bulletin applies to your vehicle, or that your vehicle will have that condition. See your Porsche Dealer for information on whether your vehicle may benefit from the information. Part numbers listed in these bulletins are for reference only. Always check with your authorized Porsche dealer to verify correct part numbers.

© Porsche Cars North America, Inc.

---

Dealership	Service Manager	_____	Shop Foreman	_____	Service Technician	_____	_____	_____	_____
Distribution	Asst. Manager	_____	Warranty Admin.	_____	Service Technician	_____	_____	_____	_____
Routing									

---

Dr. Ing. h.c. F. Porsche AG is the owner of numerous trademarks, both registered and unregistered, including without limitation the Porsche Crest®, Porsche®, Boxster®, Carrera®, Cayenne®, Cayman™, Panamera®, Tiptronic®, VarioCam®, PCM®, 911®, 4S®, FOUR, UNCOMPROMISED.® and the model numbers and distinctive shapes of Porsche's automobiles such as, the federally registered 911 and Boxster automobiles. The third party trademarks contained herein are the properties of their respective owners. Some vehicles may be shown with non-U.S. equipment. Porsche recommends seat belt usage and observance of traffic laws at all times.

Printed in the USA